

780-781XS VALVES WITH AP-RE PNEUMATIC ACTUATOR

FEATURES

The stainless steel 3-way 780XS+AP-RE (L-Port) and 781 XS+AP-RE (T-Port) steel and stainless steel ball valves provide the mixing, distribution or automatic discharge functions for pipes with non-loaded industrial fluids. It is a reduced-bore valve with an antistatic device. It is EC- and ATEX-approved. The ISO 5211 mounting pad allows the actuator to be directly assembled. The pneumatic motorisation is available in double and spring-return with numerous options.

AVAILABLE MODELS

780 XS: L-Port / **781 XS:** T-Port

1.4408 stainless steel body.

1/4" to 2" diameters.

G thread connections



LIMITS OF USE

Fluid pressure: PS	63 bar (20°C)
Fluid temperature: WT°	- 10°C / +180°C
Ambient temperature	- 20°C / + 80°C
Motor compressed air	mini 6 bar / maxi 10 bar

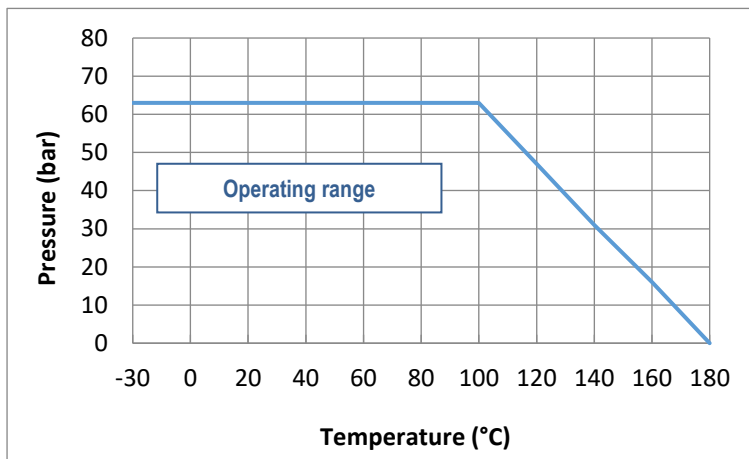

DIRECTIVES AND MANUFACTURING STANDARDS

OBJECT	Standard	ON	OBJECT	Standard
Pressure Equipment Directive 2014/68/EC	1/4" to 1": not subject		Final test	EN 12266
	1"1/4 to 2": category III	TÜV 0035	Material certificate	EN 10204
Size	EN 12516-1		Connection Motorisation	ISO 5211:
Steel grades	EN 1503-1		Actuator pilot connection	NAMUR
ATEX Directive	II 2G/D Tx zones 1,2,21 and 22	SIRA 0518	Switch box connection	VDI/VDE 3845
	EN 13463-1 and 5		SIL 3 level (the actuator alone)	EN 61508

Information given as an indication only, and subject to possible modifications

	SECTORIEL S.A. 45 rue du Ruisseau 38290 SAINT QUENTIN-FALLAVIER – FRANCE Telephone: +33 4 74 94 90 70 - Fax: +33 4 74 94 13 95 www.sectoriel.com / Email : sectoriel@sectoriel.fr	Pages	1/6
		Ref.	FT780XS+AP-RE ENG
		Rev.	02
		Date	09/2020

780-781XS VALVES WITH AP-RE PNEUMATIC ACTUATOR

CONSTRUCTION

No.	Name	Material	No.	Name	Material
1	Body	1.4408 SS	12	Lock washer	304 SS
2	Lateral ends	1.4408 SS	13	Lever nut	304 SS
3	Ball	1.4408 SS	14	Washer	304 SS
4	Seats	PTFE	15	Lever	304 SS
5	Stem	316 SS	16	Liner	PVC
6	Stem gasket	PTFE	17	Stop	304 SS
7	Body gaskets	PTFE	18	Nut	304 SS
8	Cable gland gasket	PTFE	19	O-ring	FKM
9	Washer	TFM 1600	20	Body gasket	PTFE
10	Spacer	304 SS	21	Central end	1.4408 SS
11	Belleville washer	304 SS	22	Spring	304 SS

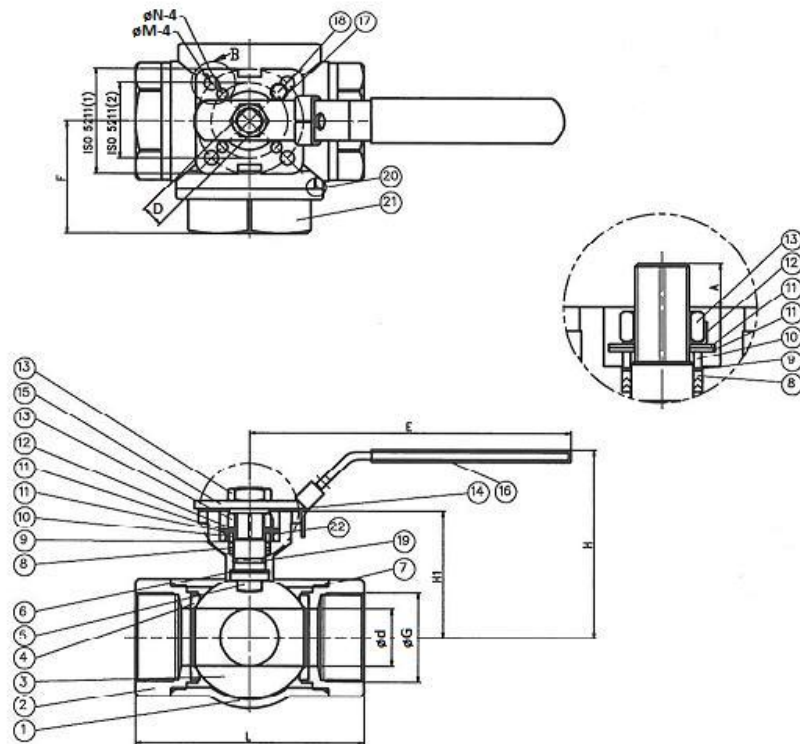

DIMENSIONS (mm)

DN (G)	1/4"	3/8"	1/2"	3/4"	1"	1"1/4	1"1/2	2"
d	11	11	12.5	16	20	25	32	38
L	75.7	75.7	75.7	86.6	103	118.2	125.8	149
H	64.9	64.9	64.9	71.6	94.3	100	115.7	124.9
F	38.3	38.3	38.3	44.7	50.8	57.7	62.6	74.3
A	8.2	8.2	8.2	9.0	11.5	11.5	15.1	15.1
E	132	132	132	132	180	180	225	225
H1	36.8	36.8	36.8	44.1	55.1	60.7	75.2	84.4
D	9	9	9	9	11	11	14	14
ISO	F03/F04	F03/F04	F03/F04	F03/F04	F04/F05	F04/F05	F05/F07	F05/F07
Weight (kg)	0.33	0.33	0.33	0.5	0.9	1.7	2.2	3.8

Information given as an indication only, and subject to possible modifications

	SECTORIEL S.A. 45 rue du Ruisseau 38290 SAINT QUENTIN-FALLAVIER – FRANCE Telephone: +33 4 74 94 90 70 - Fax: +33 4 74 94 13 95 www.sectoriel.com / Email : sectoriel@sectoriel.fr	Pages	2/6
		Ref.	FT780XS+AP-RE ENG
		Rev.	02
		Date	09/2020

780-781XS VALVES WITH AP-RE PNEUMATIC ACTUATOR

AP-RE PNEUMATIC MOTORISATION

The ALPHAIR motorisation proposed as standard comprises:

- a safety coefficient of 1.3 minimum compared to the nominal torque of the valve.
- 6 bar air non-lubricated dry motor.
- an upstream / downstream pressure difference $\Delta P=10$ bar max.

The actuator mounting is direct (except for DN 3/4" with SE actuator, mounting with yoke according to EN 15081).

DN	Double-effect	V (litres)	Time (s)*	Single-effect	V (litres)	Time (s)*
1/4"	RE 43	0.18	1	RES 43/6	0.18	1
3/8"	RE 43	0.18	1	RES 43/6	0.18	1
1/2"	RE 43	0.18	1	RES 43/6	0.18	1
3/4"	RE 43	0.18	1	RES 64/6	0.45	1
1"	RE 43	0.18	1	RES 64/6	0.45	1
1"1/4	RE 64	0.45	1	RES 76/6	0.61	1
1"1/2	RE 64	0.45	1	RES 86/6	0.98	1
2"	RE 76	0.61	1	RES 101/6	1.80	2

For any other operating conditions, please contact us.

* indicative time for actuator running empty

MOTORISATION OPTIONS

There are many options, so please contact our sales service for more information on these:

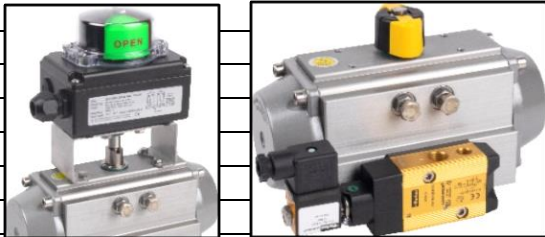
1	actuators dimensioned for a compressed air pressure of 3, 4 or 5 bar	
2	actuator dimensioned for an upstream / downstream pressure difference ΔP greater than 10 bar	
3	actuator with special coating, stainless steel actuator	
4	Actuator for very low (-60°C) or very high (+150°C) ambient temperatures.	
5	Automatic safety valve with a reinforced safety coefficient and closing time < 1s,	
6	thermal dispersion yoke for high temperature fluids	
7	100mm high steel height adjustment for installing heat-insulation	
8	special version for ATEX zones	
9	manual override with declutchable gear box	
10	compressed air filter regulator	
11	all types of piloting solenoid valves	
12	all types of switch boxes	
13	all types of positioner	
14	quick exhaust	
15	flow-rate limiters	
16	air lock	

INSTALLATION IN AN ATEX ZONE

For 780XS+RES automatic valves to be installed in ATEX 1.2 or 22 zones, this has to be specified when ordering. Our services will check of the assembly, the installation of an earthing braid, and will issue an assembly certificate. Our authorised technicians carry out these operations in the workshop. Please contact us.

The special assembly and maintenance instructions for motorised valves in the ATEX zones must be followed.

Information given as an indication only, and subject to possible modifications

	SECTORIEL S.A. 45 rue du Ruisseau 38290 SAINT QUENTIN-FALLAVIER – FRANCE Telephone: +33 4 74 94 90 70 - Fax: +33 4 74 94 13 95 www.sectoriel.com / Email : sectoriel@sectoriel.fr	Pages	3/6
		Ref.	FT780XS+AP-RE ENG
		Rev.	02
		Date	09/2020

780-781XS VALVES WITH AP-RE PNEUMATIC ACTUATOR

ASSEMBLY AND MAINTAINANCE INSTRUCTIONS

1 - Installation

1.1 - Checks

- Check that the material of the valve body is chemically compatible with the fluid.
- Check that the pressure and service conditions are compatible with the (P, T) diagram of the valve. See § "Service limits"
- Check if the ball has an L-shaped or T-shaped hole.
- Check that the fluid is clean and free of particles. The latter could scratch the ball and damage the seats, hence causing the valve to leak. If need be, install an upstream filter.
- Check that there is no risk of thermal expansion of the fluid, which could damage the seats. In the open position, a hole at the top of the ball balances the pressures between the body cavity and the flow of the fluid. As an option, we recommend a relief hole upstream of the valve for equalising the pressures for fluids such as ammonia, LPG, chlorine, etc.
- Check that the valve is not used for flow or pressure control since it is not intended for this use and there is a risk of premature wear of the seats, in particular in the event of high pressure and/or temperature.
- Check that the valve is not used on a gas which might condense at certain times during the process. In such a case, the pressure within the body cavity could become negative, which could lead to a significant deformation of the seats. Please contact us.
- Static electricity: the valve will be supplied with a ball-stem-body internal electrical continuity tester. If the service conditions require the electrical continuity of the installation, check its earthing.
- If the valve is installed in an explosive zone, you must follow the additional "IMEVMATEX" instructions.

1.2 - Storage before installation

- Follow our general "IMESTOCK" instructions for storage.

1.3 - Installation

- Before any installation, isolate the piping upstream and downstream, depressurize the piping and bring the installation to ambient temperature. Carefully clean the piping of any particle (foreign body, dust, rust, etc.) or shavings by water rinsing or air blowing.
- Correctly identify the position of the flow directions with regard to the pipe installation.
- Remove the protective tips from the valve ends.
- Check the cleanliness of the internal surfaces of the valve and if need be, clean them.
- Direction of installation: the flow directions can be identified with respect to the stem marking.
- Check the perfect alignment and the proper support of the pipe installation upstream and downstream of the valve. Alignment defects cause mechanical deformations which can block the valve or lead to leaks at the body gaskets.
- Check that the standards for the valve internal thread and pipe thread are the same.
- Cover the pipe threads using a sealing material (tow, PTFE tape, sealing glue, etc.)
- Screw the tube into the valve end clockwise, as shown in the diagram below.
- Check the sealing of the connection using a suitable test (hydrostatic test or leak detection spray).

2 - Service

- If a hot fluid flows across the valve, do not touch the valve surface.
- Always operate the valve slowly and smoothly.
- Opening clockwise, closing anti-clockwise.

Information given as an indication only, and subject to possible modifications

	SECTORIEL S.A. 45 rue du Ruisseau 38290 SAINT QUENTIN-FALLAVIER – FRANCE Telephone: +33 4 74 94 90 70 - Fax: +33 4 74 94 13 95 www.sectoriel.com / Email : sectoriel@sectoriel.fr	Pages	4/6
		Ref.	FT780XS+AP-RE ENG
		Rev.	02
		Date	09/2020

780-781XS VALVES WITH AP-RE PNEUMATIC ACTUATOR

3 - Servicing

3.1 - Frequency of servicing

- The servicing frequency depends upon the use of the valve, of the type of fluid, of its velocity, of its frequency of operation, of the cycles of rise and fall in pressure and temperature.
- Before any intervention, isolate the upstream and downstream pipe installation using the valves provided for this purpose. Depressurize the pipe installation and bring it to ambient temperature.
- If the lever has to be removed, do that before disassembling the body.
- To disassemble the central body, unscrew the lateral ends (items 2). Removal
- To remove the ball from the body, turn the stem by a quarter turn.

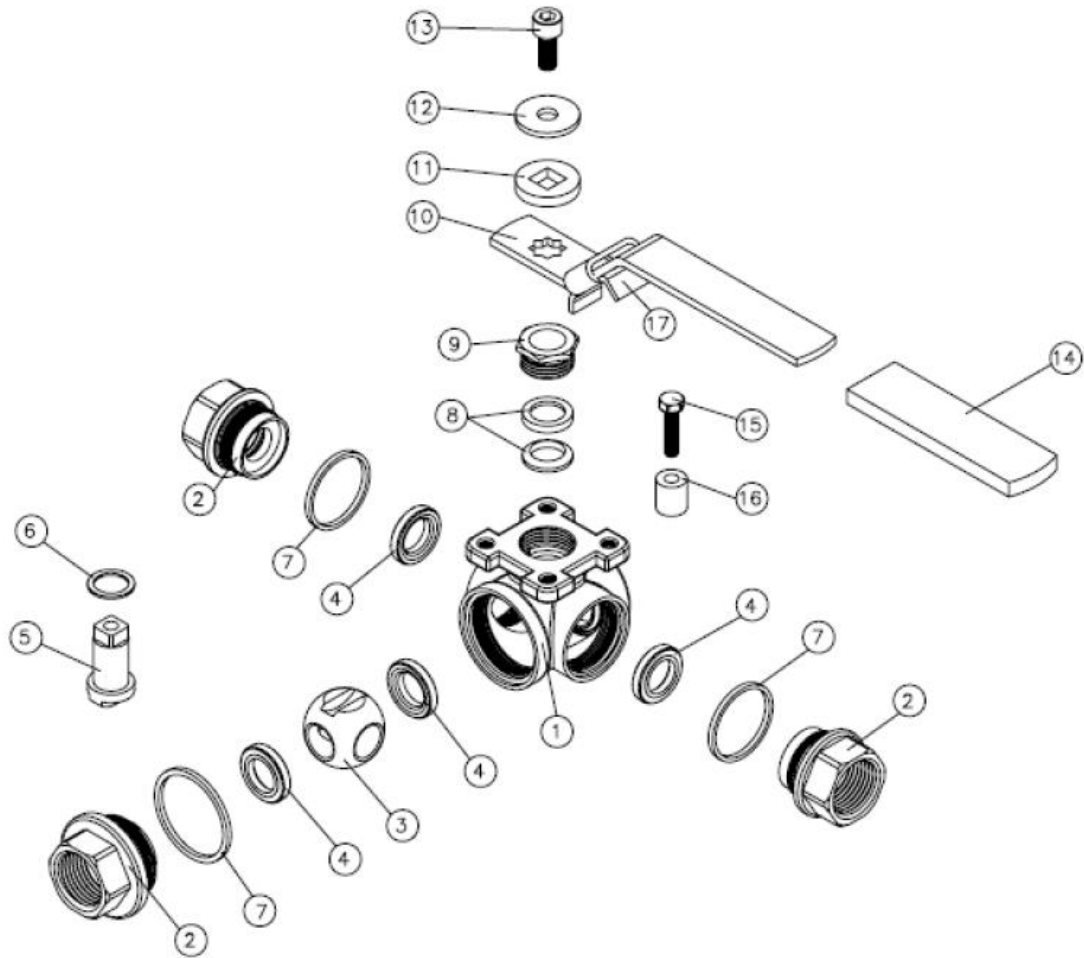

3.2 - Inspecting the state of the valve and possible repair

- Check the state of the ball (Item 3): it has to be clean and unscratched. If the cleaning or polishing is not possible, replace it (see the § on spare parts).
- Check the state of the seats (4.1 and 4.2): they must not be deformed, nor scratched, nor worn, or dirty. Otherwise, replace them with parts from the gasket kit.
- Check the state of the packing gland (6 and 8): no leak should be found at the stem and the rings should not be excessively worn. If need be, replace the gaskets.
- Check the state of the body gaskets (7.1, 7.2, and 7.3). Replace them if necessary.
- Reassemble the different parts of the valve, following the tightening torques shown in the table below.
- Check that the stem manoeuvring is smooth. Perform about ten manoeuvres.

Information given as an indication only, and subject to possible modifications

	SECTORIEL S.A. 45 rue du Ruisseau 38290 SAINT QUENTIN-FALLAVIER – FRANCE Telephone: +33 4 74 94 90 70 - Fax: +33 4 74 94 13 95 www.sectoriel.com / Email : sectoriel@sectoriel.fr	Pages	5/6
		Ref.	FT780XS+AP-RE ENG
		Rev.	02
		Date	09/2020

780-781XS VALVES WITH AP-RE PNEUMATIC ACTUATOR

SPARE PARTS

DN	Gasket kit	Ball	Handle
Reference mark	4-6-7-8	3	14
1/4"	982882	Please contact us.	Please contact us.
3/8"	982883	Please contact us.	Please contact us.
1/2"	982884	Please contact us.	Please contact us.
3/4"	982885	Please contact us.	Please contact us.
1"	982886	Please contact us.	Please contact us.
1"1/4	982887	Please contact us.	Please contact us.
1"1/2	982888	Please contact us.	Please contact us.
2"	982889	Please contact us.	Please contact us.

Information given as an indication only, and subject to possible modifications

	SECTORIEL S.A. 45 rue du Ruisseau 38290 SAINT QUENTIN-FALLAVIER – FRANCE Telephone: +33 4 74 94 90 70 - Fax: +33 4 74 94 13 95 www.sectoriel.com / Email : sectoriel@sectoriel.fr	Pages	6/6
		Ref.	FT780XS+AP-RE ENG
		Rev.	02
		Date	09/2020

60 Seulement pour
DN20 avec RES64

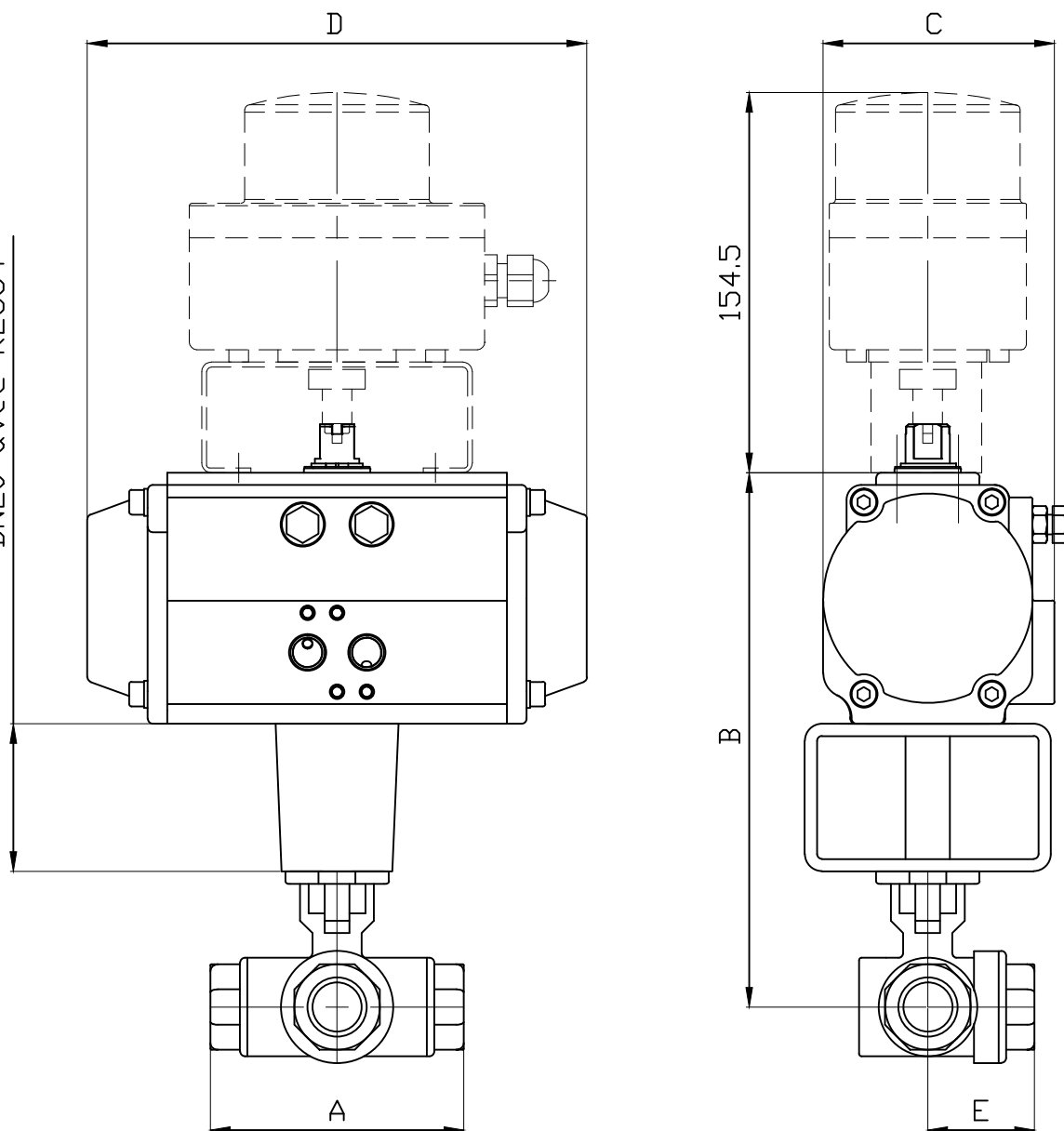

DN	08		10		15		20		25		32		40		50	
ALPHAIR	RE43	RES43	RE43	RES43	RE43	RES43	RE43	RES64	RE43	RES64	RE64	RES76	RE64	RES86	RE76	RES101
A	75.7	75.7	75.7	75.7	75.7	75.7	86.6	86.6	103	103	118.2	118.2	125.8	125.8	149	149
B	98.8	98.8	98.8	98.8	98.8	98.8	106.1	190.1	117.1	141.1	146.7	162.7	161.2	187.2	186.4	211.4
C	63.5	63.5	63.5	63.5	63.5	63.5	63.5	86	63.5	86	86	94	86	104	94	120
D	141	141	141	141	141	141	141	155	153.5	155	155	203	155	239	203	261
E	38.3	38.3	38.3	38.3	38.3	38.3	44.7	44.7	50.8	50.8	57.7	57.7	62.6	62.6	74.3	74.3
KG	1.63	1.73	1.6	1.68	1.55	1.64	1.92	3.45	2.56	3.58	4.17	5.8	5.39	8.41	8.78	12.55

Informations données à titre indicatif et sous réserve de modifications éventuelles
data subject to alteration

Ech: /	Date :18/07/2019	Dessiné par : E.D.	Tolérances générales : +/- 0.2	Modifications	Date	REV.
ROBINET A TOURNANT SPHERIQUE 780-781XS/BALL VALVE 780-781XS + ACTIONNEUR ALPHAIR RE / PNEUMATIC ACTUATOR ALPHAIR RE + BFC /LIMIT SWITCH BOX				Matière :		
 45, Rue du Ruisseau 38297 SAINT QUENTIN FALLAVIER				Poids <Kg> :		
				Traitement : SANS Plan n° Ens 1369		

780XS PERÇAGE EN L 780XS L Port

Pour commander indiquer 2 positions successives
Indicate the 2 successive positions when ordering

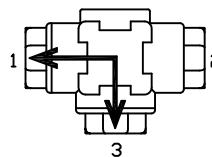
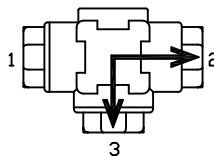
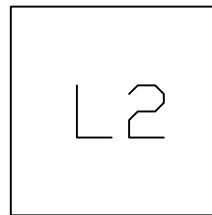
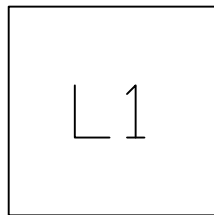

ACTIONNEUR SIMPLE EFFET : Fermeture dans le sens horaire,
sens inverse: plus value,nous consulter.
SPRING-RETURN : Clockwise closure,
for counterclockwise closure additional price, please contact us.

781XS PERÇAGE EN T 781XS T Port

Pour commander indiquer 2 positions successives
Indicate the 2 successive positions when ordering

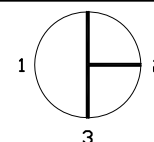
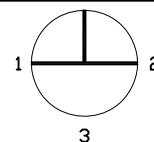
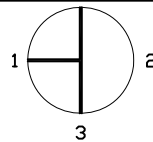
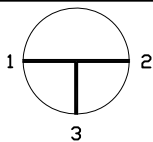
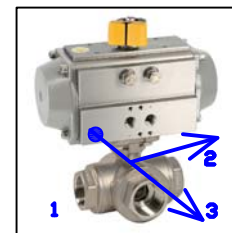
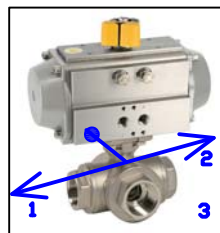
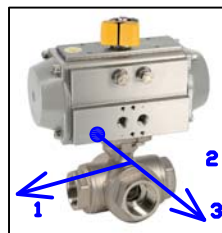
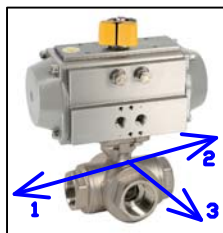
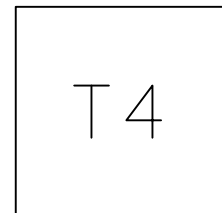
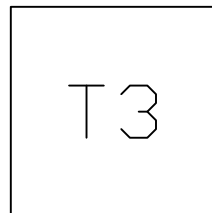
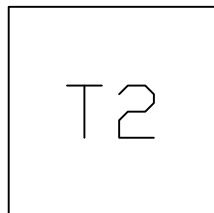
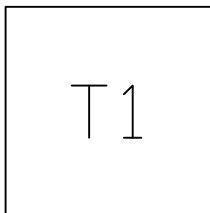

ACTIONNEUR SIMPLE EFFET : Fermeture dans le sens horaire,
sens inverse: plus value,nous consulter.
SPRING-RETURN : Clockwise closure,
for counterclockwise closure additional price, please contact us.

Informations données à titre indicatif et sous réserve de modifications éventuelles
data subject to alteration

Ech:	Date 19/09/2019	Dessiné par : E.D.	Tolérances générales : +/- 0.2	Modifications	Date	REV.
ROBINET A TOURNANT SPHERIQUE 780-781XS/BALL VALVE 780-781XS POSITIONS POUR COMMANDE/POSITIONS WHEN ORDERING				Matière :		
				Poids (Kg) :		
				Traitement : SANS		
				Plan n° Ens 1371		

45, Rue du Ruisseau
38297 SAINT QUENTIN FALLAVIER



RE SERIES

**PNEUMATIC ACTUATORS
WITH EXTERNAL ADJUSTMENT**

ROTATION 90°



English edition



Alphaair

Distributed in FRANCE by
SECTORIEL

2017

ALPHAIR PNEUMATIC ACTUATORS EXTERNAL ADJUSTMENT New "RE" SERIES

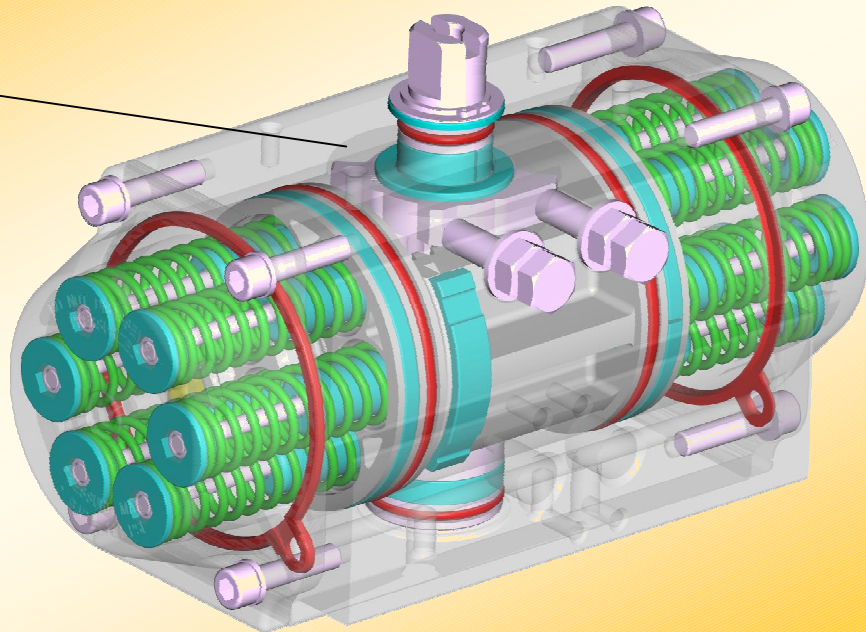
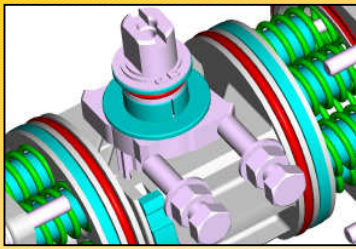

The new series of ALPHAIR Pneumatic Actuators with special "External Adjustment" system meets every quality and precision requirement.

The new "External Adjustment" system guarantees maximum precision on rotation adjusting, for normal and heavy conditions, in any application field.

Suitable for every requirement, ALPHAIR Pneumatic Actuators with special "External Adjustment" system are carefully designed for maximum torque rating and maximum lifetime.

More compact, heavy and reliable, ALPHAIR Pneumatic Actuators with special "External Adjustment" system can be easily assembled on every kind of valve.

STANDARD VERSION FEATURES

- **EN AW 6063 extruded aluminium Body**, inside surface finishing Ra= 0,4-0,6. 25 µ Hard Anodizing.
- **EN AB 46100 die-cast aluminium alloy Pistons**, 15 micron Anodizing.
- **EN AB 46100 die-cast aluminium alloy Covers**, painted with 60-80 µ polyester powder.
- **Carbon steel Shaft**, 20 µ nickel-plated. Stainless Steel AISI 304 (A2) or AISI 316 (A4) as Optional.
- **External adjusting gear, made of Stainless Steel AISI 316 (A4).**
- **AISI 316 (A4) Stainless Steel Screws.**
- **NBR nitrile nubber seals.** FPM/FKM or SILICONE on request.
- Acetalic resin + 20% PTFE bearings, for low friction, easily replaceable for maintenance. PA66 or LEXAN on request.
- Pre-compressed Spring Cartridges, easily replaceable for maintenance, 60-80 micron polyester painted.
- High performances Syntetic Grease as standard grease. Special grease supplied for HIGH/LOW/VERY LOW temperatures.
- Several special protections available for chemical, pharmaceutical, food and industrial environments.
- Rotation adjustment $\pm 5^\circ$ in both opening and closing position. Assembly precision $\pm 1^\circ$, made by electronic devices.
- Double lower drilling for valve fastening and centering, according to ISO 5211-DIN 3337 Standards.
- Double square lower female shaft key (starlike), according to ISO 5211-DIN 3337 Standards for assembly on valves with square key on line (0°) and diagonal key (45°).
- Solenoid connections according to NAMUR VDI\VDE-3845 Standards.
- Top drilling for accessories fastening, and upper shaft end according to NAMUR VDI\VDE-3845 Standards.
- Position indicator on request, enabling switch-box assembly on top.
- Aluminium adhesive nameplates, with progressive serial number punched.
- Lubrication carried out by the manufacturer, guaranteed for min. 1.000.000 operations.
- Running test and 100% seal test carried out with electronic equipment and certification of every individual product.
- Standard execution for temperatures from -20°C to $+80^\circ\text{C}$ (optional, special execution for extreme temperatures).
- Conformity for use in explosive environment; Ex II 2 GD "c" protection type.
- According to EN 15714-3 design and manufacture standard requirements.

FEEDING	TEMPERATURE RANGE	SUPPLY PRESSURE	ROT. ADJUSTMENT
Dry or lubricated 50 um filtered compressed air	Standard $-20^\circ +80^\circ\text{C}$ ($-4 +175^\circ\text{F}$) HIGH Temperature $-20^\circ +150^\circ\text{C}$ ($-4 +300^\circ\text{F}$) LOW Temperature $-40^\circ +80^\circ\text{C}$ ($-40 +175^\circ\text{F}$) VERY LOW Temperature $-60^\circ +80^\circ\text{C}$ ($-76 +175^\circ\text{F}$)	8 bar/120 psi Continuous working - 10 bar/142 psi MAXIMUM	$\pm 5^\circ$ in both OPENING and CLOSING position

DOUBLE ACTING TORQUES IN Nm

TYPE	AIR SUPPLY PRESSURE (bar)									
	1	2	3	4	5	6	7	8	9	10
RE 043	-	-	6,5	8,7	10,9	13,0	15,2	17,3	19,5	21,7
RE 051	3,3	6,7	10,0	13,4	16,7	20,1	23,4	26,8	30,1	33,5
RE 064	5,9	11,8	17,8	23,7	29,6	35,5	41,4	47,4	53,3	59,2
RE 076	11,8	23,5	35,3	47,1	58,9	70,6	82,4	94,2	105,9	117,7
RE 086	17,2	34,5	51,7	68,9	86,1	103,4	120,6	137,8	155,0	172,3
RE 101	27,5	54,9	82,4	109,8	137,3	164,8	192,2	219,7	247,1	274,6
RE 116	43,7	87,4	131,1	174,9	218,6	262,3	306,0	349,7	393,4	437,1
RE 126	56,6	113,3	169,9	226,5	283,2	339,8	396,4	453,0	509,7	566,3
RE 146	88,4	176,7	265,1	353,4	441,8	530,1	618,5	706,9	795,2	883,6
RE 161	114,9	229,7	344,6	459,5	574,3	689,2	804,1	918,9	1034	1149
RE 181	156,6	313,1	469,7	626,3	782,9	939,4	1096	1253	1409	1565
RE 201	215,3	430,6	646,0	861,3	1077	1292	1507	1723	1938	2153
RE 241	372,5	745,0	1118	1490	1863	2235	2608	2980	3353	3725
RE 271	539,2	1078	1617	2157	2696	3235	3774	4314	4853	5392
RE 331	911,5	1823	2734	3646	4558	5469	6835	7292	8204	9115
RE 421	1671	3342	5013	6684	8354	10025	11696	13367	-	-

SINGLE ACTING TORQUES IN Nm

TYPE	SPRING SET	AIR SUPPLY PRESSURE (bar)												SPRING TORQUE	
		3		4		5		6		7		8		90°	0°
		0°	90°	0°	90°	0°	90°	0°	90°	0°	90°	0°	90°		
RE 043	SR 3/3 SR 4/4	-	-	-	-	7,1	4,1	9,3	6,3	11,5	8,5	13,7	10,7	6,8	3,8
RE 051	SR 3/3 SR 4/4 SR 5/5 SR 6/6	5,8 4,4	4,3 2,3	9,1 7,8	7,6 5,7	12,5 11,1	10,9 9,0	15,8 14,4	14,3 12,3	19,2 17,8	17,6 15,7	22,5 21,1	21,0 19,0	5,8 7,8	4,3 5,7
RE 064	SR 3/3 SR 4/4 SR 5/5 SR 6/6	10,7 8,4	7,1 3,5	16,6 14,3	13,0 9,4	22,5 20,2	18,9 15,4	28,5 26,1	24,8 21,3	34,4 32,0	30,8 27,2	40,3 38,0	36,7 33,1	10,7 14,3	7,1 9,4
RE 076	SR 3/3 SR 4/4 SR 5/5 SR 6/6	21,1 16,3	14,3 7,2	32,8 28,1	26,0 19,0	44,6 39,8	37,8 30,8	56,4 51,6	49,6 42,5	68,1 63,4	61,3 54,3	79,9 75,2	73,1 66,1	21,1 28,1	14,3 19,0
RE 086	SR 3/3 SR 4/4 SR 5/5 SR 6/6	33,8 27,9	17,8 6,6	51,1 45,1	35,1 23,8	68,3 62,3	52,3 41,0	85,5 79,6	69,5 58,2	102,7 96,8	86,7 75,5	120,0 114,0	104,0 92,7	33,8 45,1	17,8 23,8
RE 101	SR 3/3 SR 4/4 SR 5/5 SR 6/6	50,1 39,3	32,3 15,6	77,5 66,8	59,7 43,0	105,0 94,2	87,2 70,5	132,5 121,7	114,7 98,0	159,9 149,2	142,1 125,4	187,4 176,6	169,6 152,9	50,1 66,8	32,3 43,1
RE 116	SR 3/3 SR 4/4 SR 5/5 SR 6/6	80,7 63,9	50,5 23,5	124,4 107,6	94,2 67,3	168,1 151,3	137,9 111,0	211,8 195,0	181,6 154,7	255,5 238,7	225,3 198,4	299,3 282,4	269,0 242,1	80,7 107,6	50,5 67,3
RE 126	SR 3/3 SR 4/4 SR 5/5 SR 6/6	105,0 83,3	64,9 29,9	161,6 140,0	121,5 86,5	218,2 196,6	178,2 143,2	274,9 253,2	234,8 199,8	331,6 309,9	291,4 256,4	388,1 366,5	348,0 313,0	105,0 140,0	64,9 86,6
RE 146	SR 3/3 SR 4/4 SR 5/5 SR 6/6	162,5 128,3	102,6 48,4	250,8 216,6	190,9 136,8	339,2 305,0	279,3 225,1	427,5 393,3	367,7 313,5	515,9 481,7	456,0 401,9	604,3 570,1	544,4 490,2	162,5 216,6	102,6 136,8
RE 161	SR 3/3 SR 4/4 SR 5/5 SR 6/6	202,7 155,3	141,9 74,3	317,5 270,2	256,8 189,2	432,4 385,1	371,6 304,1	547,3 499,9	486,5 418,9	662,1 614,8	601,4 533,8	777,0 729,7	716,2 648,7	202,7 270,2	141,9 189,2
RE 181	SR 3/3 SR 4/4 SR 5/5 SR 6/6	281,6 218,8	188,2 94,3	438,1 375,4	344,7 250,9	594,7 532,0	501,3 407,5	751,3 688,5	657,9 564,0	907,8 845,1	814,5 720,6	1064 1002	971,0 877,2	281,6 375,4	188,2 250,9
RE 201	SR 3/3 SR 4/4 SR 5/5 SR 6/6	386,2 299,6	259,8 131,1	601,5 514,9	475,13 46,4	816,8 730,2	690,5 561,8	1032 945,5	905,8 777,1	1247 1160	1436 1376	1712 1608	1523 1408	386,2 514,9	259,8 346,4
RE 241	SR 3/3 SR 4/4 SR 5/5 SR 6/6	664,0 521,8	453,6 232,3	1037 885,4	826,2 604,8	1409 1258	1199 977,4	1782 1630	1571 1350	2154 2003	1944 1722	2527 2376	2316 2095	664,0 885,4	453,6 604,8
RE 271	SR 3/3 SR 4/4 SR 5/5 SR 6/6	912,5 677,5	705,1 400,8	1452 1217	1244 940,2	1991 1756	1783 1479	2530 2295	2323 2019	3069 2834	2862 2558	3608 3373	3401 3097	912,5 1217	705,1 940,1
RE 331	SR 3/3 SR 4/4 SR 5/5 SR 6/6	1626 1257	1108 565,8	2538 2168	2020 1477	3450 3080	2931 2389	4361 3992	3843 3301	5273 4903	4755 4212	6184 5815	5666 5123	1626 2168	1108 1477
RE 421	SR 3/3 SR 4/4 SR 5/5 SR 6/6	2999 2327	2014 1014	4670 3998	3685 2685	6340 5669	5356 4356	8011 7340	7026 6027	9682 9011	8697 7698	11353 9369	10368 9369	2999 3998	2014 2685

Torque by air

Torque by springs

DIMENSIONS – European Sizes in millimetres

VDI/VDE-3854

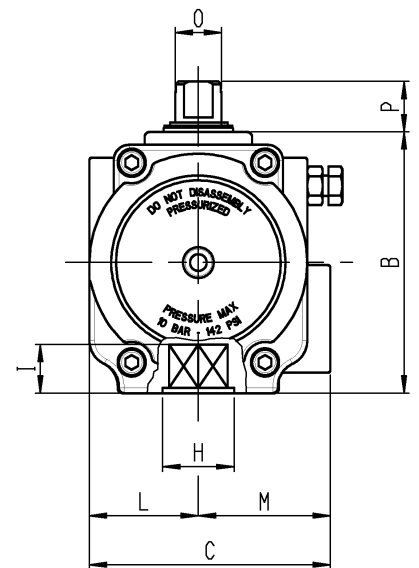
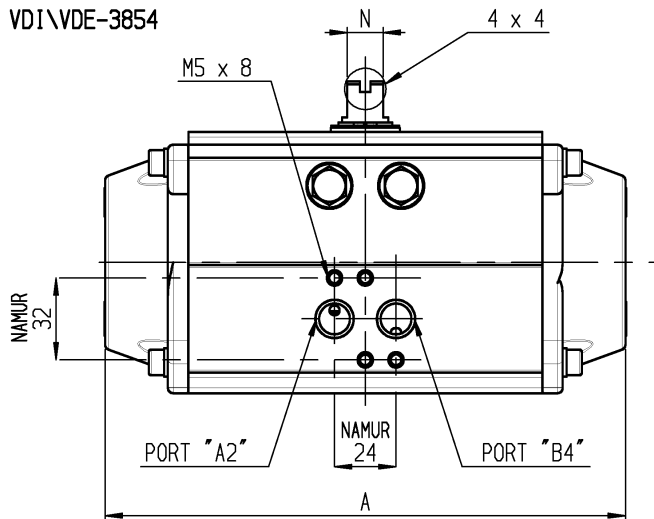

VDI/VDE-3854

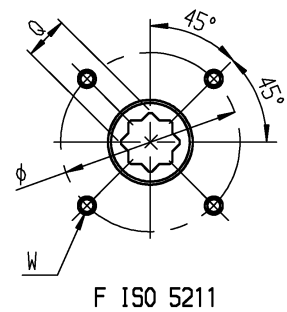
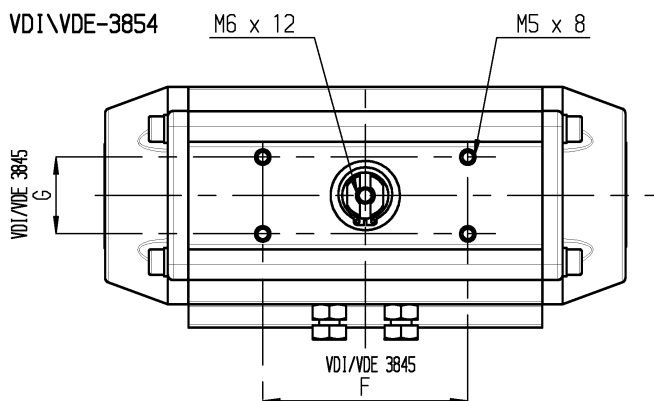

POSITION	TYPE															
	RE 043	RE 051	RE 064	RE 076	RE 086	RE 101	RE 116	RE 126	RE 146	RE 161	RE 181	RE 201	RE 241	RE 271	RE 331	RE 421
A	141	138	155	203	239	261	304	333	398	424	482	528	604	684	850	940
B	62	69	86	102	112	127	145,5	157,5	177	196	220	246	298	332	414	542
C	63,5	75	86	94	104	120	133,5	144,5	164,5	182	203,5	222	300	352	400	528
VDI/VDE 3845 F x G	80 x 30 50 x 25	80 x 30					80 x 30 130 x 30			130 x 30						200 x 50
L	27	33,5	38	42,5	49	55	63,5	69,5	80,5	89	99,5	110	150	176	190	234
M	36,5	41,5	48	51,5	55	65	70	75	84	93	104	112	150	176	210	294
Port A Port B DIN 259	1/8" GAS-NPT			1/4" GAS-NPT									1/2" GAS-NPT			
N x O	8 x 12			14 x 18			27 x 36			32 x 42		42 x 60	55 x 80			
P	20						30			50						80
Q x I	9 x 10 11 x 13	9 x 10 11 x 13	9 x 10 11 x 13 14 x 16	11 x 13 14 x 16 17 x 20	14 x 16 17 x 20	14 x 16 17 x 20 22 x 25	17 x 20 22 x 25	17 x 20 22 x 25 27 x 29	22 x 25 27 x 29	22 x 25 27 x 29	27 x 29 36 x 39	27 x 29 36 x 39	36 x 39 46 x 50	36 x 39 46 x 50	*46 x 50 55 x 60	*55 x 60 75 x 80
F ISO 5211	F04	F04	F05/07	F05/07	F05/07	F07/10	F07/10	F07/10	F10/12	F10/12	F10/12	F14	F14	F16	F16/25	F25/30
Optional	F03/05	F03/05	F3/5/7			F5/7/10		F7/10/12			F14	F10/12	F(12)/16	F(12)/16		F(16)
Volume DE	0,180 lt	0,300 lt	0,500 lt	0,700 lt	1,000 lt	1,800 l	2,900 lt	3,700 lt	6,100 lt	7,900 lt	11,2 lt	14,4 lt	19,2 lt	32,2 lt	62,8 lt	131 lt
Volume SE	0,072 lt	0,120 lt	0,200 lt	0,280 lt	0,400 lt	0,720 l	1,160 lt	1,480 lt	2,440 lt	3,160 lt	4,480 lt	5,760 lt	7,680 lt	12,9 lt	25,1 lt	52,4 lt

POSITION	F ISO 5211											
	F03	F04	F03/05	F05	F05/07	F5/7/10	F07/10	F10/12	F14	F16	F25	F30
Ø (W)	Ø 36 (M5x8)	Ø 42 (M5x8)	Ø 36 (M5x8) Ø 50 (M6x9)	Ø 50 (M6x9)	Ø 50 (M6x9) Ø 70 (M8x12)	Ø 50 (M6x9) Ø 70 (M8x12) Ø 102 (M10x15)	Ø 70 (M8x12) Ø 102 (M10x15)	Ø 102 (M10x15) Ø 125 (M12x18)	Ø 140 (M16x24)	Ø 165 (M20x30)	Ø 254 (M16x24) N°8 FORI	Ø 298 (M20x35) N°8 FORI
H	25	30	25	35	35 (RE 086=40)	40	55	85 (RE 161=75)	100	130	200	200

CONSTRUCTION PARTS – SPECIFICATIONS

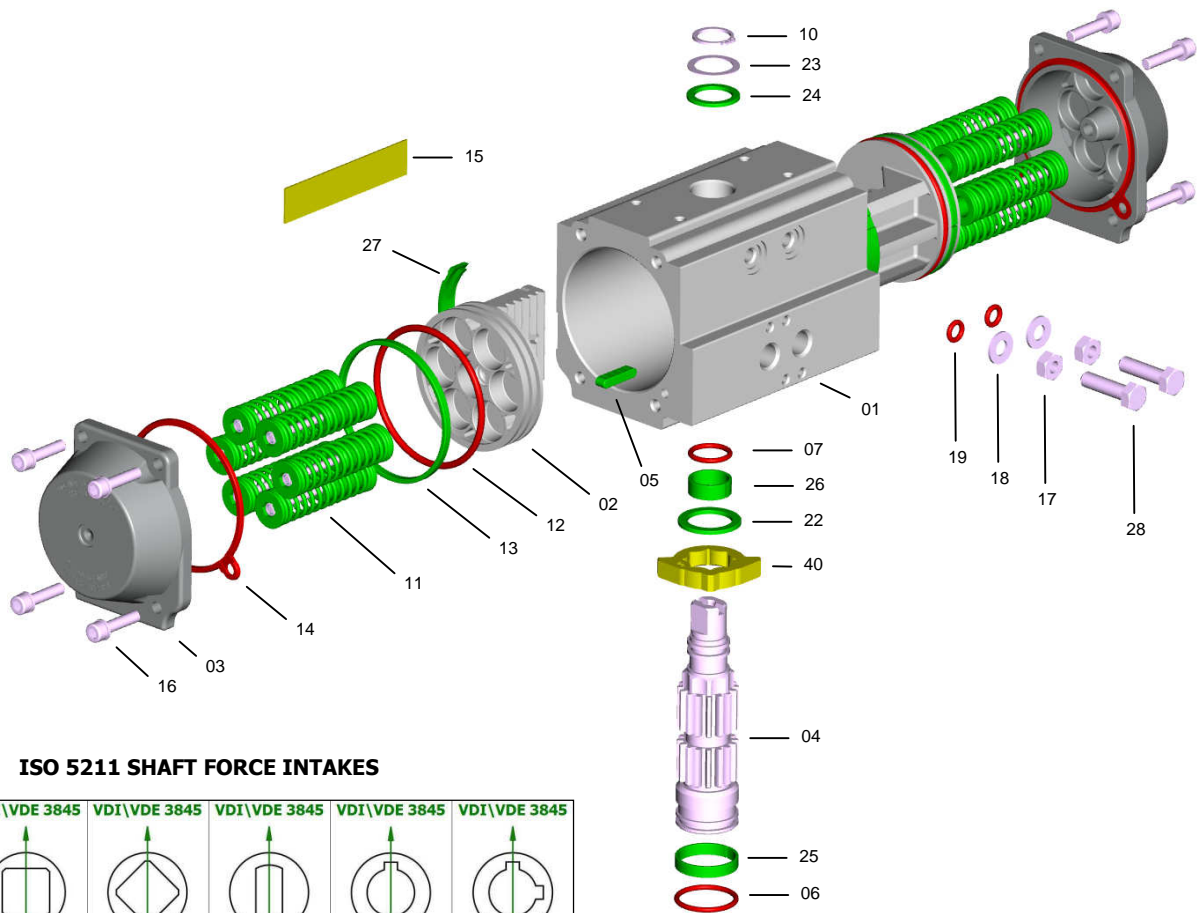

ISO 5211 SHAFT FORCE INTAKES

VDI\VDE 3845	VDI\VDE 3845	VDI\VDE 3845	VDI\VDE 3845	VDI\VDE 3845	VDI\VDE 3845
STANDARD ALPHAIR S = L/D	L	D	H	V	W

PART	QUANTITY	DESCRIPTION	MATERIAL	SPECIFICATION	PROTECTION
1	1	Body	Extruded aluminium alloy	EN AW 6063 T6	A - N - TF
2	2	Piston	Aluminium alloy	EN AB 46100 T6	A
3	2	Cover	Aluminium alloy	EN AB 46100 T6	N - V - TF
4	1	Shaft	Carbon steel Stainless Steel – optional	ASTM A-105 AISI 304 (A2) AISI 316 (A4)	N
5 *	2	Antiejection key	Acetalic resin – PA66 – PA66 – LEXAN		
6 *	1	Lower shaft O-Ring	NBR – FPM\FKM – Silicone – Silicone		
7 *	1	Upper shaft O-Ring	NBR – FPM\FKM – Silicone – Silicone		
10 *	1	Seeger ring	Carbon steel		N
11	0 ... 12	Spring cartridge	Carbon steel, PA 66, Stainless Steel	C-98	V
12 *	2	Piston O-Ring	NBR – FPM\FKM – Silicone – Silicone		
13 *	2	Piston head bearing	Acetalic resin – PA66 – PA66 – LEXAN		
14 *	2	Cover gasket	NBR – FPM\FKM – Silicone – Silicone		
15	1	Nameplate	Aluminium		
16	4 + 4	Cover fastening screw	Stainless Steel	AISI 304 (A2)	
17	2	Nut	Stainless Steel	AISI 304 (A2)	
18	2	Washer	Stainless Steel	AISI 304 (A2)	
19 *	2	O-Ring	NBR – FPM\FKM – Silicone – Silicone		
22 *	1	Gear antifriction washer	Acetalic resin – PA66 – PA66 – LEXAN		
23 *	1	Shaft thrust washer	Stainless Steel	AISI 304 (A2)	
24 *	1	Shaft antifriction washer	Acetalic resin – PA66 – PA66 – LEXAN		
25 *	1	Lower shaft pilot ring	Acetalic resin – PA66 – PA66 – LEXAN		
26 *	1	Upper shaft pilot ring	Acetalic resin – PA66 – PA66 – LEXAN		
27 *	2	Piston bearing	Acetalic resin – PA66 – PA66 – LEXAN		
28	2	Adjusting gear screw	Stainless Steel	AISI 304 (A2)	
40	1	Adjusting gear	Stainless Steel	AISI 316 (A4)	

* SPARE PARTS SET: Standard, Special HIGH Temperatures, Special LOW Temperatures, Special EXTRA LOW Temperatures

PROTECTIONS

A = Anodizing N = chemical Nickel-plating V = Painting TF = Anodizing+PTFE

COATINGS – MATERIAL TREATMENTS

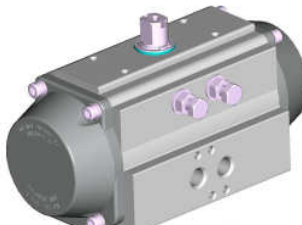
	AV standard	DESCRIPTION				APPLICATION FIELD
		Body	Covers	Pistons	Shaft	
	Anodizing	Polyester painting	Anodizing	High phosphorous nickel-plating (12%) opt. AISI 304 (A2) opt. AISI 316 (A4)	- Industry, general use.	
	Colour	Gray	Gray	Brown		Polished steel
Thickness	25 µ	60/80 µ	15 µ	20 µ		

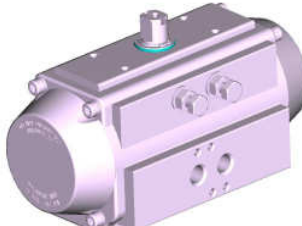
	NN	DESCRIPTION				APPLICATION FIELD
		Body	Covers	Pistons	Shaft	
	High phosphorous nickel-plating (12%)	High phosphorous nickel-plating (12%)	Anodizing	High phosphorous nickel-plating (12%) opt. AISI 304 (A2) opt. AISI 316 (A4)	- Industry, general use. - Caustic soda. - Detergents. - Low alkaline solutions.	
	Colour	Polished steel	Polished steel	Brown		Polished steel
Thickness	20 µ	20 µ	15 µ	20 µ		

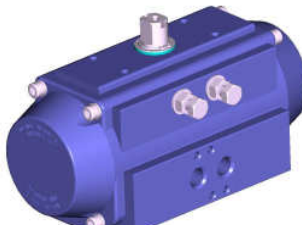
	TF TF	DESCRIPTION				APPLICATION FIELD
		Body	Covers	Pistons	Shaft	
	Anodizing + PTFE coating	Anodizing + PTFE coating	Anodizing	High phosphorous nickel-plating (12%) opt. AISI 304 (A2) opt. AISI 316 (A4)	- Industry, general use. - Low alkaline and low acid solutions. - Marine environments. - High temperatures.	
	Colour	Blue	Blue	Brown		Polished steel
Thickness	Anodizing 25 µ PTFE 15 µ	Anodizing 15 µ PTFE 15 µ	15 µ	20 µ		

ANODIZING

Anodizing is an electrolytic process that produces anodic coating on aluminum, called alumine, with high thickness. Alumine is one of the most hard known materials, with resistance values up to 400-600 HV (45-65 HRC); properties and features of Anodizing (alumine thickness 25 micron) are well know and appreciated both for mechanical and chemical resistance.

- **Best friction and corrosion resistance, best surface hardness, good thermic and electrical insulation.**

ELECTROLESS NICKEL-PLATING

Chemical nickel-plating is an electroless coating process that gives nickel layers at extremely constant thickness also on sharp angles, blind-holes, threads and grooves recess. During the process, nickel is combined with phosphor at a percentage of 12% (high-phosphor). The obtained surface hardness is about 400-480 HV (45-55 HRC).

- **Best friction and corrosion resistance, best surface hardness, best external appearance similar to S.S., increased resistance to alcali and detergents in sanitary and food applications.**

POLYESTER PAINTING

Polyester painting is obtained through powder coatings on polarized parts, by means of light differences in electrical potentials. After applications, parts are baked in order to polymerize and let the painting be spread to avoid micro-porosity. The best elasticity can be obtained at 60/80 micron thickness; a satisfactory adhesion can be assured by sandblasting or brushing, and by special degreasing baths of the rough pieces to be treated.

- **Better corrosion resistance, protection against crashes, better external appearance and several available colours, resistance to chemicals.**

ANODIZING + PTFE COATING

As further improvement of the hard anodising treatment on aluminium alloys, protective coatings made of PTFE are used; this material is known for its particular chemical and physical features. On these double treated surfaces, oxide hardness and low roughness (internal slipping parts) is summed to the chemical resistance and the excellent qualities as a thermic barrier of PTFE (external surface, subject to corrosion).

- **Better corrosion resistance, protection against high temperatures and crashes, extreme resistance to chemicals and in marine environments.**

AISI 304 (A2) OR AISI 316 (A4) STAINLESS STEEL SHAFT - OPTIONAL

AISI 304 (A2) and AISI 316 (A4) Stainless Steel shafts, with their great corrosion resistance, are recommended for special applications such as: marine and chemical environments, food and pharmaceutical industry, high temperature applications.



Via Molino Emili, 16 - 25030 MACLODIO (BS) Italy - Tel. +39 030 97 86 61/2- Fax +39 030 97 86 63
www.alphair.it - www.alphapompe.it

Tous droits réservés - Annule et remplace toutes les versions précédentes - Les données sont sujettes à changement sans préavis - Non garantie l'exactitude

COMPANY WITH QUALITY SYSTEM CERTIFIED BY DNV GL = ISO 9001 =					EN UNI 10204 3.1	СЕРТИФИКАТ  СООТВЕТСТВИЯ
---	---	---	---	---	----------------------------	---